

NX-Plasma Hardware Manual - NPN - Version 5.1

NevexTech LTD

Contents

1	Introduction	2
1.1	What is the NX-Plasma Motion Controller?	3
1.2	Key Features	3
2	Connecting the NX-Plasma Controller	4
2.1	X, Y, Z, A, B Driver Connectors	5
2.2	Input Connectors	8
2.3	Output Connector	10
2.4	Plasma Power Source Connector	11
2.5	24V Power Supply Connector	14
2.6	Ethernet Connector	14
2.6.1	Configuring IP Address in Windows 10	14
2.7	Mounting Diagram	16
3	Ohmic Sensor	17
4	Technical Support	19
4.1	Motors Not Turning	19
4.2	Motors Only Turn in One Direction	19
4.3	Technical Support	19
5	WARRANTY	20
5.1	Warranty is void when:	20
5.2	Precautions for Choosing the Products	20
5.3	Limitation of Liabilities	21
5.3.1	Exclusion of Certain Damages	21
5.3.2	Maximum Liability	21
5.3.3	Accuracy of Information	21
5.3.4	Acknowledgment of Limitations	21
5.3.5	Legal Counsel Advised	21

1 Introduction

Welcome to the NX-Plasma Hardware manual. This manual is designed to provide you with a comprehensive understanding of the NPN version of the NX-Plasma Motion Controller. Whether you are setting up a new plasma cutting system or upgrading your existing setup, this manual will guide you through the process of connecting, configuring, and utilizing the controller to its fullest potential.

The NX-Plasma Motion Controller represents a cutting-edge solution tailored specifically for managing plasma cutting tables. As an essential companion to the NX-Plasma CNC software, this controller takes charge of critical tasks such as controlling motor movements, managing input and output signals, and overseeing torch height adjustments during the cutting process.

To ensure you make the most of this manual, we recommend familiarizing yourself with the key features of the NX-Plasma Motion Controller, outlined in the next section. Whether you are an experienced professional or a newcomer to the world of CNC and plasma cutting, this manual aims to provide clear instructions and insights to empower you in achieving optimal performance and precision in your plasma cutting endeavors.

Please note that this manual is tailored to the NPN version of the controller. Therefore, we encourage you to verify that you have the correct version before proceeding with the installation and setup process. As you delve into the subsequent sections, you'll discover detailed information about connecting the controller, utilizing its various features, troubleshooting common issues, and understanding the warranty terms and limitations.

We are excited to embark on this journey of exploring the capabilities of the NX-Plasma Motion Controller with you. By the end of this manual, you'll be equipped with the knowledge and confidence to seamlessly integrate the controller into your plasma cutting workflow and unlock its full potential.

Let's dive in and begin your journey with the NX-Plasma Motion Controller!

1.1 What is the NX-Plasma Motion Controller?

The NX-Plasma Motion Controller is a specialized motion controller designed specifically for managing plasma cutting tables. It is meant to work in conjunction with the NX-Plasma CNC software, taking charge of tasks such as controlling motor paths, managing outputs, monitoring input signals, and overseeing torch height adjustment during the cutting process.



Figure 1: The NX-Plasma Motion Controller

1.2 Key Features

- Supports control for up to 5 axes (NPN signal).
- Integrated torch height control.
- Equipped with 16 optically isolated inputs.
- Features 5 solid-state relay outputs.
- Includes an analog input for plasma arc voltage.
- Built-in solid-state relay for initiating plasma cutting.
- Dedicated input for arc-ok signal.
- Step/Dir interface for servo or stepper drivers.
- Maximum frequency of 200 kHz.
- Operates with 24-volt inputs/outputs.
- Features a 10/100 Mbps Ethernet interface.

2 Connecting the NX-Plasma Controller

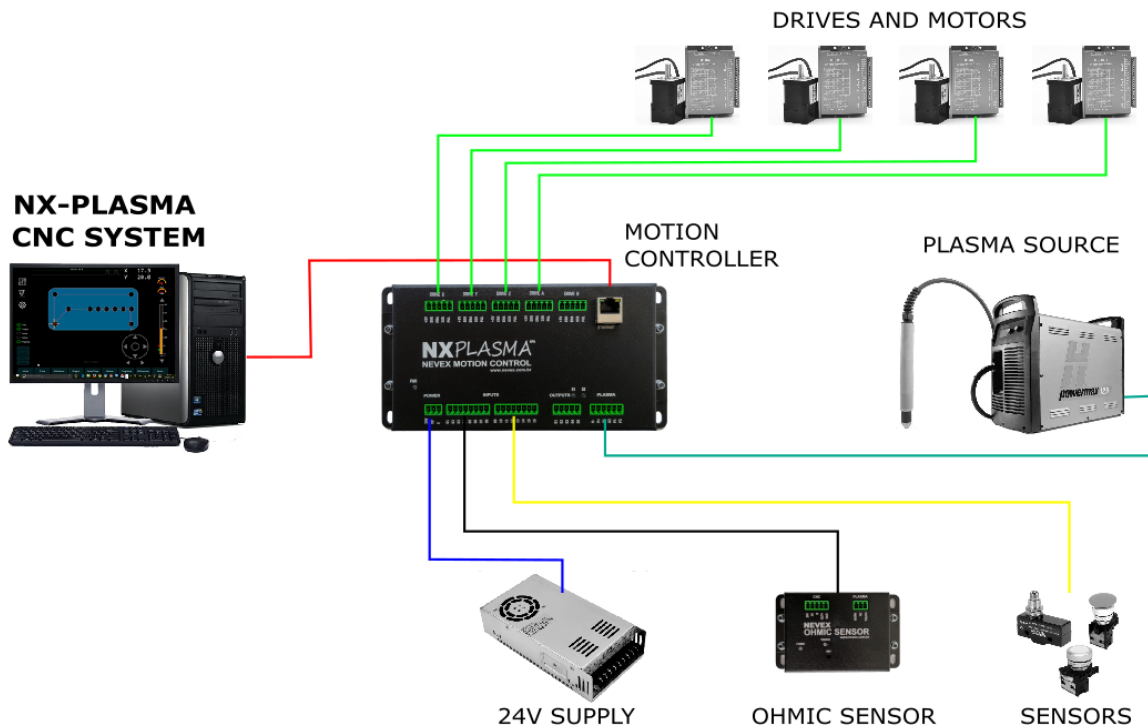

Figure 2: NX-Plasma CNC Overview

The NX-Plasma motion controller interfaces with the plasma cutting system through six different groups of connectors:

- Driver Connectors (X, Y, Z, A, B),
- Input Connectors,
- Output Connector,
- Plasma Source Connector,
- 24V Power Supply Connector,
- Ethernet Connector.

The driver connectors are of the NPN type, where the signal is low (0 volts) when the pin is active. The input and output pin connectors are of the PNP type, where the signal is high (24 volts).

2.1 X, Y, Z, A, B Driver Connectors

The motion controller offers the capability to manage up to 5 axes, each equipped with a dedicated connector housing the necessary input and output lines to oversee a singular motor driver. Whether the driver is of the stepper or servo type, provided that it adheres to Step/Dir command logic, it can be controlled seamlessly. Notably, the output signals are of the NPN (open collector) variety, signifying that the controller will drive the output pin to zero volts upon activation. These outputs can handle voltages of up to 24 volts, with a current capacity of 10mA each.

The STEP signal is a series of rapid pulses that serve to advance the motor’s position by one step, a fundamental unit of movement. Each pulse corresponds to a discrete movement increment. On the other hand, the DIR (direction) signal governs the rotation direction of the motor. The DIR signal’s state, either low or high, dictates whether the motor rotates in a clockwise or counterclockwise direction. In essence, the STEP signal triggers the motion, while the DIR signal determines the direction of rotation.

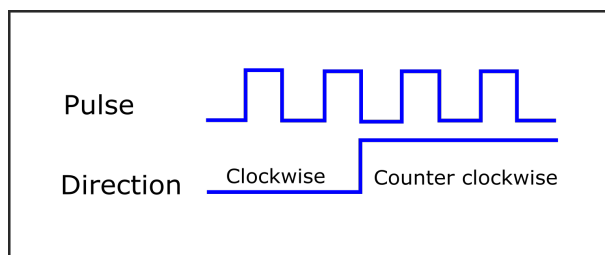

Figure 3: STEP / DIR Signals

For the driver to recognize a step pulse as valid, the pulse signal duration must meet the minimum pulse duration required by the driver. A typical value ranges between 1 microsecond and 5 microseconds. Refer to the driver’s manual for the precise value. This parameter is adjustable in the NX-Plasma CNC software. The polarity of the direction signal is also adjustable to ensure motors rotate in the desired direction, either clockwise or counterclockwise.

The controller provides a connector for each axis, streamlining the driver’s connection to the motion controller. The signals from this connector are NPN type, where the signal is low (0 volts).

Table 1: Driver connector pins

Pin:	Signal	I/O	Description
5	Step	Out	Step pulse signal
4	Direction	Out	Direction signal

Pin:	Signal	I/O	Description
3	Enable	Out	Enable signal
2	Error	In	Error indication
1	+5V	Out	+5V Voltage

Stepper motor drivers should be connected as depicted below:

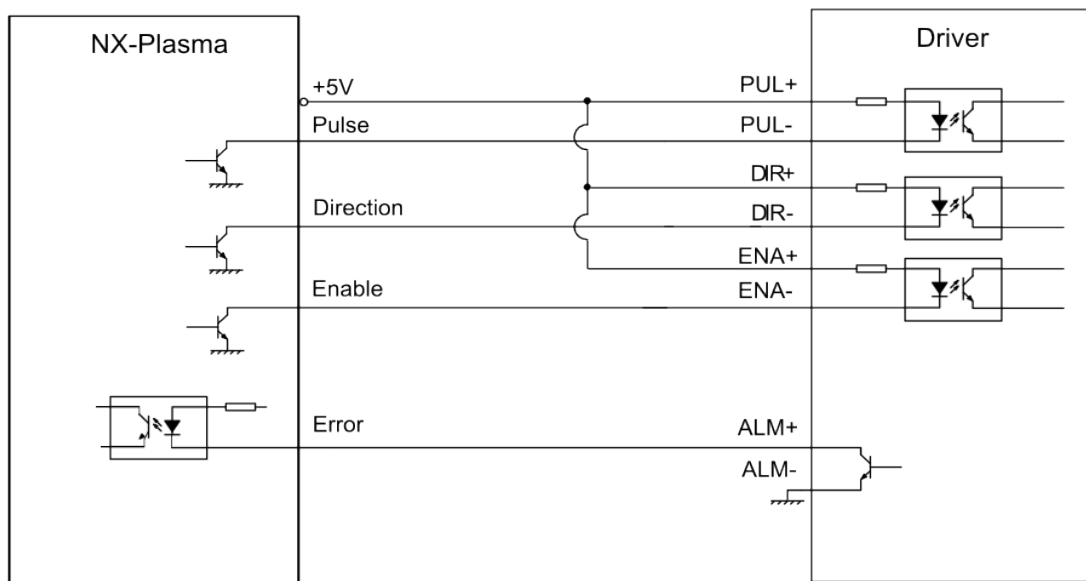

Figure 4: Driver Connection

The enable signal can be utilized to activate the motion drivers. If left unconnected, the default behavior of the drivers is to be enabled. Use this as a safety measure once the motors are functioning correctly. This signal is NPN. This signal is activated when virtual output 6 is activated.

The error signal is an input used in servo scenarios, where the servo generates a negative (NPN) signal to signify proper functioning. When the servo enters an alarm state due to a servo-related issue, the servo must deactivate the signal, and the controller will indicate the error.

Each axis error input is associated with a unique input pin number, as listed in the table below.

Table 2: Axis error input is associated with a unique input pin number

Axis:	Virtual Input
X	19
Y	20
Z	21
A	22
B	17

2.2 Input Connectors

The controller features 16 versatile general-purpose inputs meticulously crafted to facilitate sensor integration, including limit switches and emergency buttons, among other applications. These inputs are divided between two connectors, each boasting 8 inputs for convenient connectivity. Operating in adherence to the PNP principle, these inputs spring to action when a 24-volt signal is applied the input pin.

Table 3: Pins for Input Connector 1

Pin	Description
1	Input 1
2	Input 2
3	Input 3
4	Input 4
5	Input 5
6	Input 6
7	Input 7
8	Input 8

Table 4: Pins for Input Connector 2

Pin	Description
1	Input 9
2	Input 10
3	Input 11
4	Input 12
5	Input 13
6	Input 14
7	Input 15
8	Input 16

IMPORTANT: To ensure safety, it is advised to consistently employ NC (normally closed) switches when wiring limit switches, reference switches, or emergency switches. This guarantees a continuous signal flow to the controller, and it's only when this signal is interrupted that the input gets triggered. This setup enables the CNC system to promptly detect wire breaks, thereby initiating an alarm.

An added advantage is the ability to link multiple switches to a single input. For instance, you have the flexibility to connect all limit switches to one input and allocate another input for all reference switches. This approach not only conserves input resources but also opens up additional inputs for other essential functions.

2.3 Output Connector

The controller is equipped with 5 general-purpose outputs designed to activate relays and other low-current devices. These outputs generate 24 volts when triggered. The maximum output current is 50mA.

IMPORTANT: Subjecting an output to a short circuit can lead to its impairment or malfunction. A short circuit occurs when there's an unintended connection between the output terminal and a low-resistance pathway. In such cases, a significantly higher current than the output's designed capacity flows through the circuit. This excessive current can generate excessive heat, potentially causing components within the output to overheat or even fail. To prevent this, it's crucial to ensure that outputs are properly connected and not subjected to short circuits, as such occurrences can compromise the functionality and longevity of the output.

Table 5: Pins of the output connector

Pin	Description
1	Output 1
2	Output 2
3	Output 3
4	Output 4
5	Output 5

2.4 Plasma Power Source Connector

The controller utilizes three distinct signals from the plasma power source: arc voltage, arc OK, and plasma start signals.

All three signals must be connected to the controller for proper CNC system operation. These signals should be connected to the plasma power source connector on the motion controller.

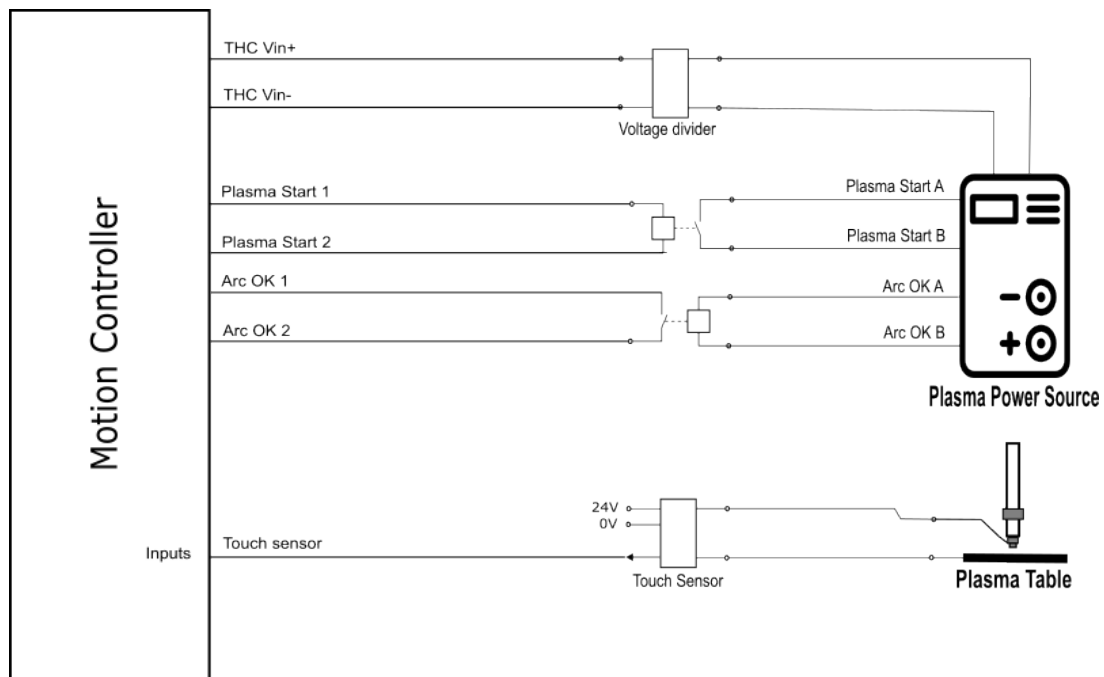

Figure 5: Plasma Power Source Connections

Arc Voltage Inputs - These two inputs should be connected to the arc voltage monitoring output of the plasma power source. Most plasma power sources provide a voltage divided by 50, and that's the value to be used. The input voltage should range from 0V to 5V, corresponding to an arc voltage of 0V to 250V. Note that these inputs are polarized, and polarity must be respected; use a multimeter to check the polarity of the plasma power source signals.

IMPORTANT: If your plasma power source doesn't have a voltage divider, you will need to add one between the plasma output and the controller input. Not using a voltage divider will damage the controller.

Arc OK - This signal is provided by the plasma power source when it detects that an arc has been created, indicating to the CNC controller to initiate the cutting operation. The two provided pins should be shorted (dry contact) to indicate that arc OK is active. Internally, they are connected to an opto-coupled input to provide electrical isolation, and when activated, virtual input number 18 is triggered.

Plasma Start - This signal is used to instruct the plasma power source to initiate the arc. Most plasma power sources provide two pins that, when shorted, will initiate the arc. The NX-Plasma motion controller features an internal solid-state relay for this purpose. This relay is a low-current relay and should not be used for any demanding current input. This relay is activated when virtual output number 7 is activated.

Table 6: Plasma Connector Pins

Pin	Signal	Type	Description
1,2	Arc Voltage	Input	Arc voltage divided by 50.
3,4	Arc OK	Input	Requires dry contact to activate. In an open circuit, presents 24V voltage at the arc OK terminals.
5,6	Plasma Start	Output	Normally open. Closed with a dry contact through a solid-state relay.

Plasma power source connectors may vary from supplier to supplier and from model to model. Refer to the plasma power source user manual for the correct pinout of the connectors. Below, we illustratively present an example of a plasma power source CNC connector:

Table 7: Example connection with NX-Plasma controller

NX-Plasma	Plasma Power Source
Pin 1	Pin 5
Pin 2	Pin 6
Pin 3	Pin 12
Pin 4	Pin 14
Pin 5	Pin 3
Pin 6	Pin 4

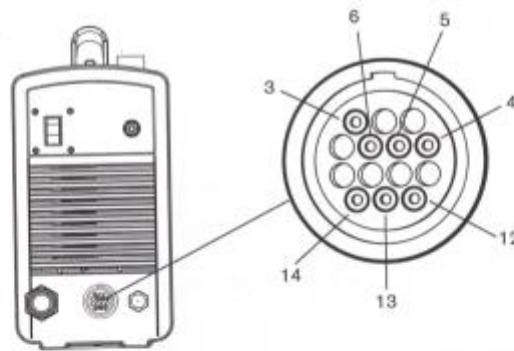

Refer to the following table when connecting the Powermax45 to a torch height controller or CNC controller with a machine interface cable.

Signal	Start (start plasma)	Transfer (start machine motion)	Ground	50:1 voltage divider
Type:	Input	Output	Ground	Output
Notes:	Normally open. 18 VDC open circuit voltage at START terminals. Requires dry contact closure to activate.	Normally open. Dry contact closure when the arc transfers. 120 VAC/1 A maximum at the machine interface relay or switching device (supplied by the customer).		Divided arc signal of 50:1 (provides a maximum of 7 V).
Connector sockets	3, 4	12, 14	13	5, 6
Cable wires	Green, black	Red, black	Green/yellow	Black, red

Figure 6: Hypertherm CNC Connector

2.5 24V Power Supply Connector

The NX-Plasma controller requires a 24-volt, 5-watt power supply to operate. This power supply is connected to the controller through the controller’s power supply connector. For improved noise immunity, a separate power supply should be used for the controller and another for the motor drives.

Table 8: Power supply connector pins

Pin	Signal	Description
1	+24V	Positive 24V supply
2	0V	Return of power supply voltage
3	Ground	Earth ground connection

2.6 Ethernet Connector

For enhanced reliability in an industrial environment, the controller utilizes a network connection for communication with the CNC control software.

To ensure proper communication, the network adapter on the computer running the CNC control software needs to be configured to use a static IP address within the same subnet as the controller (192.168.0.*). Since the controller comes pre-configured with IP 192.168.0.100, we recommend setting the PC’s IP to 192.168.0.2.

2.6.1 Configuring IP Address in Windows 10

- Open the Control Panel.
- Click on Network and Sharing Center.
- In the left panel, click on the Change adapter settings link.
- Right-click on your network adapter and select Properties.
- Select Internet Protocol Version 4 (TCP/IPv4).
- Click the ‘Properties’ button.
- Choose the option Use the following IP address.
- Set the IP address to 192.168.0.2.

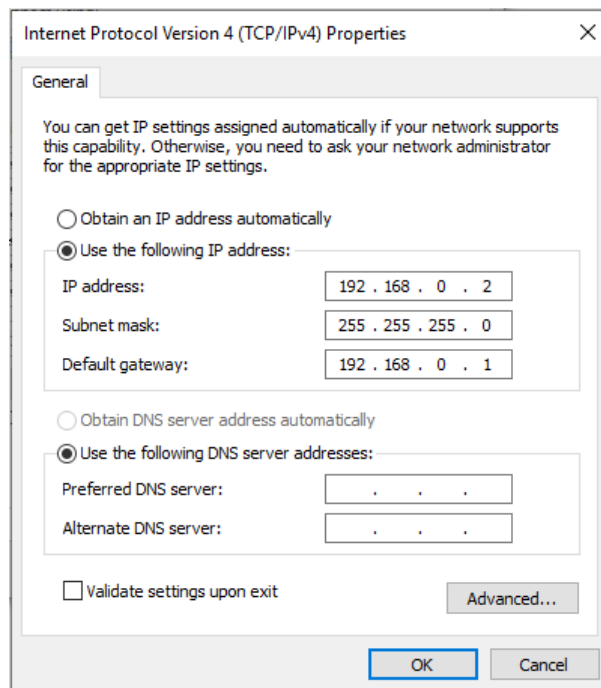

Figure 7: Network Adapter Settings

- Set the Subnet mask to 255.255.255.0.
- Set the Default gateway to 192.168.0.1.
- Click OK. To verify communication with the controller, use the Ping command (in the command prompt window) to the controller’s default IP address, 192.168.0.100.

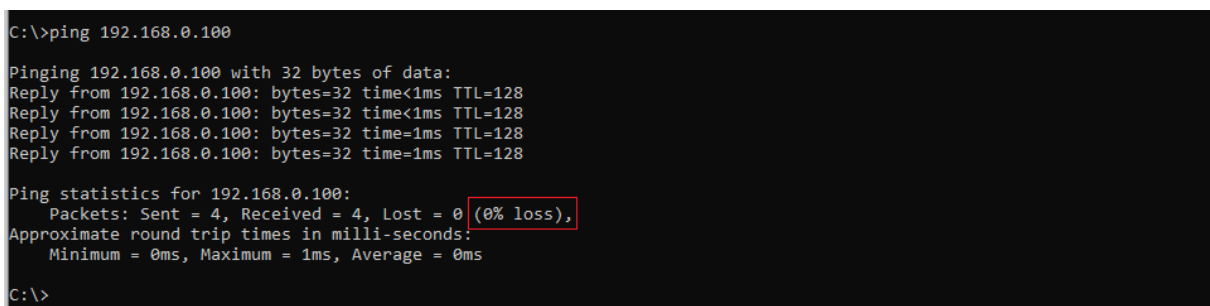

Figure 8: Ping Command Results

Ensure that no packets are lost during the test. Packet loss indicates unreliable communication and should not be used for controlling CNC equipment. Also, ensure that the maximum response times are below 5ms.

2.7 Mounting Diagram

The NX-Plasma controller is mounted using four screws, and the mounting dimensions are depicted below:

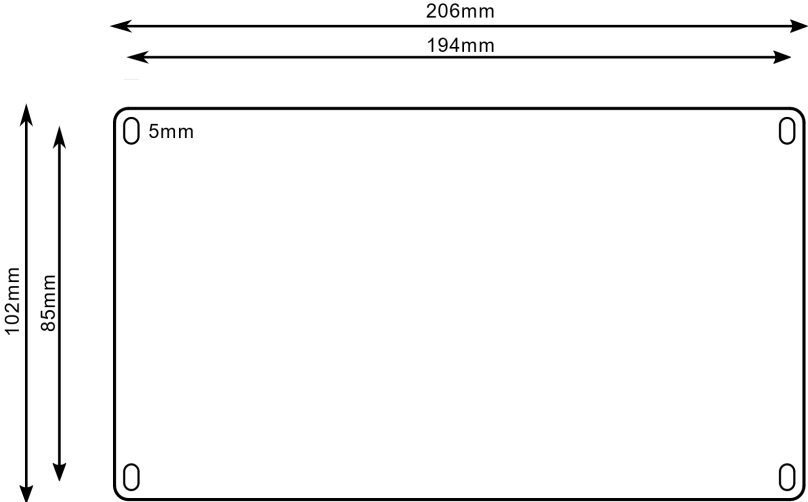

Figure 9: Mounting Diagram

3 Ohmic Sensor

The Ohmic Sensor is used to detect the initial height of the metal plate by sensing contact between the torch sensor cup and the metal plate to be cut. When the sensor detects that contact has been made, it signals the controller by activating its output.

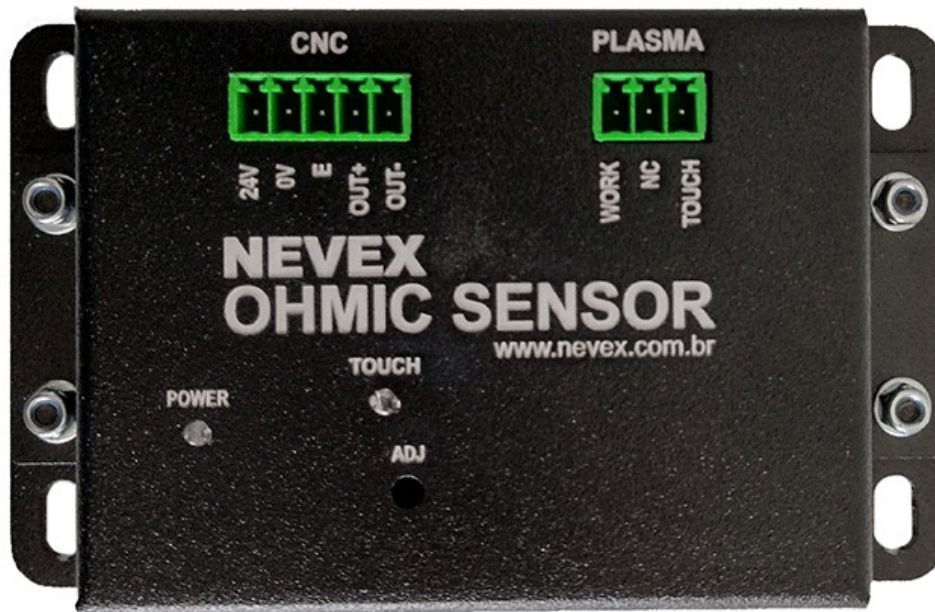

Figure 10: Ohmic Sensor

When the ohmic sensor detects contact with the metal plate, it triggers the output signal and turns on the blue LED.

You can adjust the sensitivity of the touch sensor using the adjustment potentiometer with a small Philips screwdriver.

Table 9: Ohmic Sensor Connections

Signal	Description
+24V	Positive 24V supply
0V	Return of power supply voltage
GND	System ground
Out+	Positive opto-isolated output
Out-	Negative opto-isolated output

Signal	Description
--------	-------------

For use with the NX-Plasma controller, the “Out+” signal should be connected to 24 Volts, and the “Out-” signal should be connected to one of the controller’s 16 inputs. The touch function input of the NX-Plasma CNC must be configured to reflect the used input number, and the polarity should be set to positive.

Table 10: Torch and Table Connections

Signal	Description
Work	Plasma table ground
NC	Not connected
Torch	Torch touch sensor

4 Technical Support

4.1 Motors Not Turning

- Check the wiring.
- Verify the step pulse duration configuration. Some stepper motor drivers ignore values below 3 μ s.

4.2 Motors Only Turn in One Direction

- Check the wiring of the direction signal. Without a direction signal, drivers can only be commanded to turn in one direction.

4.3 Technical Support

If you encounter issues or have any questions regarding the installation or operation of this product, please contact NevexTech's technical support department via email at support@nxplasma.com.

5 WARRANTY

Please review the following product warranty details before using this product.

- The NevexTech warranty applies to manufacturing defects or malfunctions for a period of three months after installation at the company's or customer's premises, or for a period less than 1 month (counted from the purchase date) after product shipment, whichever is shorter, is selected.
- In terms of product delivery, NevexTech will provide the standard product without customer-specific configurations or application adjustments, and NevexTech is not responsible for on-site adjustments or product testing.

5.1 Warranty is void when:

- Damages due to improper storage, mishandling, careless accidents, customer-made software or hardware design
- Damages due to product modifications without manufacturer's consent
- Damages resulting from using the product outside of specifications
- Repairs of damages: There will be a fee for repairing damages and replacing parts.

5.2 Precautions for Choosing the Products

- These products have been manufactured for general industrial use and have NOT been designed or manufactured to be incorporated into devices or systems used for purposes related to human life.
- Before using the products for special purposes such as nuclear power, electricity, motor vehicles, aerospace, medical, or passenger transportation, please contact NevexTech.
- These products have been manufactured under strict quality control. However, when installing the product where accidents or serious losses may occur if the product fails, install appropriate backup or safety functions in the system.

5.3 Limitation of Liabilities

5.3.1 Exclusion of Certain Damages

To the extent permitted by applicable laws, NevexTech shall not be liable for any direct, indirect, incidental, consequential, special, or punitive damages, including but not limited to damages for loss of profits, business interruption, loss of data, or any other commercial or economic damages, arising out of or in connection with the use or inability to use the product, even if NevexTech has been advised of the possibility of such damages.

5.3.2 Maximum Liability

In no event shall NevexTech's total liability for any claims, losses, or damages exceed the purchase price of the product. This limitation of liability shall apply regardless of the legal theory upon which any claim for damages is based, whether in contract, tort, negligence, strict liability, or otherwise.

5.3.3 Accuracy of Information

NevexTech does not assume any liability for the accuracy, reliability, or completeness of any information provided in the product manual or related materials. The customer is responsible for verifying the suitability of the product for their specific applications.

5.3.4 Acknowledgment of Limitations

The above limitations of liability are fundamental elements of the agreement between the customer and NevexTech. Some jurisdictions do not allow the exclusion or limitation of incidental or consequential damages, so the above limitations may not apply to all customers.

5.3.5 Legal Counsel Advised

By using the product, the customer agrees to these limitations of liabilities and acknowledges that they have been advised to seek legal counsel before using the product in any critical or high-risk applications.